



New Products for 2006

Oldsmobile Big Block Serpentine Conversion Kit



Shown with our optional Futura Billet air cleaner

Now Oldsmobile owners can get March Performance Style and Reliability.

Our Oldsmobile serpentine conversion kits for 2005 replaces the troublesome V-belt accessory drive on big block Oldsmobile motors, to eliminate belt slippage and throwing.

Precision CNC machined from solid billet 6061-T6 aluminum to fit perfectly and handle high torque and vibration. "No Polishing" clear powdercoating, for maintenance-free operation. Pulley are standard ratio as OEM to preserve full electrical charging and engine cooling. kits come with stainless steel adjustment rods for perfect belt tensioning.

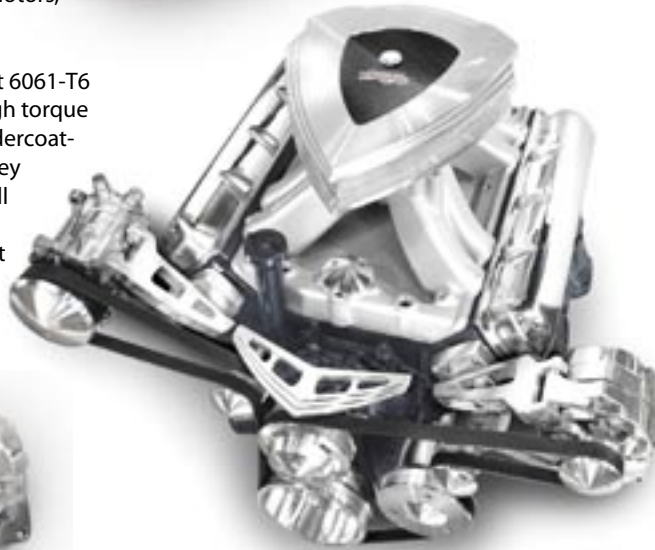

Saginaw Power Steering Pump Kit.

Use your old pump and save the cost of remote power steering lines and reservoir

Application

Oldsmobile Big Block 442-455c.i. to drive Alternator, Water Pump, A/C and Power Steering or Alternator, Water Pumps and Power Steering and Alternator and Water Pump only.



Oldsmobile 455ci Serpentine Conversion

Now Oldsmobile owners can get March Performance Style and Reliability. This serpentine conversion kits replaces the troublesome V-belt accessory drive on big block Oldsmobile motors, to eliminate belt slippage and belt throwing. The Street Rod version of this kit allows rotation of the Alt. and A/C to a taller but narrower setup, (see our web site for pictures and info on this kit.) Pulley are standard ratio as OEM to preserve full electrical charging and engine cooling.

Kit comes complete with stainless steel tensioning rods and chrome moly rod ends for high performance operation. All necessary hardware included. Matching serpentine pulleys are precision CNC machined

Shown with Futura Air Cleaner

NEW!

Application:

455ci Big block Oldsmobile, Pontiac Firebird.

Kit Includes:

- Combination Alternator power steering bracket with idler, Alternator relocater arm, tensioners and hardware.
- Crank pulley, water pump pulley with nose cover
- Alternator pulley with fan and nose cover
- Remote power steering pump cover with pulley and pulley nose cover
- A/C kit includes A/C bracket with idler, compressor nose cover
- Wing accent
- Tensioning rods and rod ends
- Grade 8 mounting hardware

Optional Accessories:

- #P315 Remote power steering pump
- #9650 March billet alternator
- #16011 Wing Accent (included in 16070 kit)
- #450 Power Steering Reservoir
- #3222 Stainless Steel Braided Power Steering Lines
- #P150 March Performance Chrome Water Pump

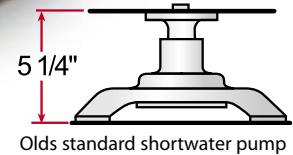
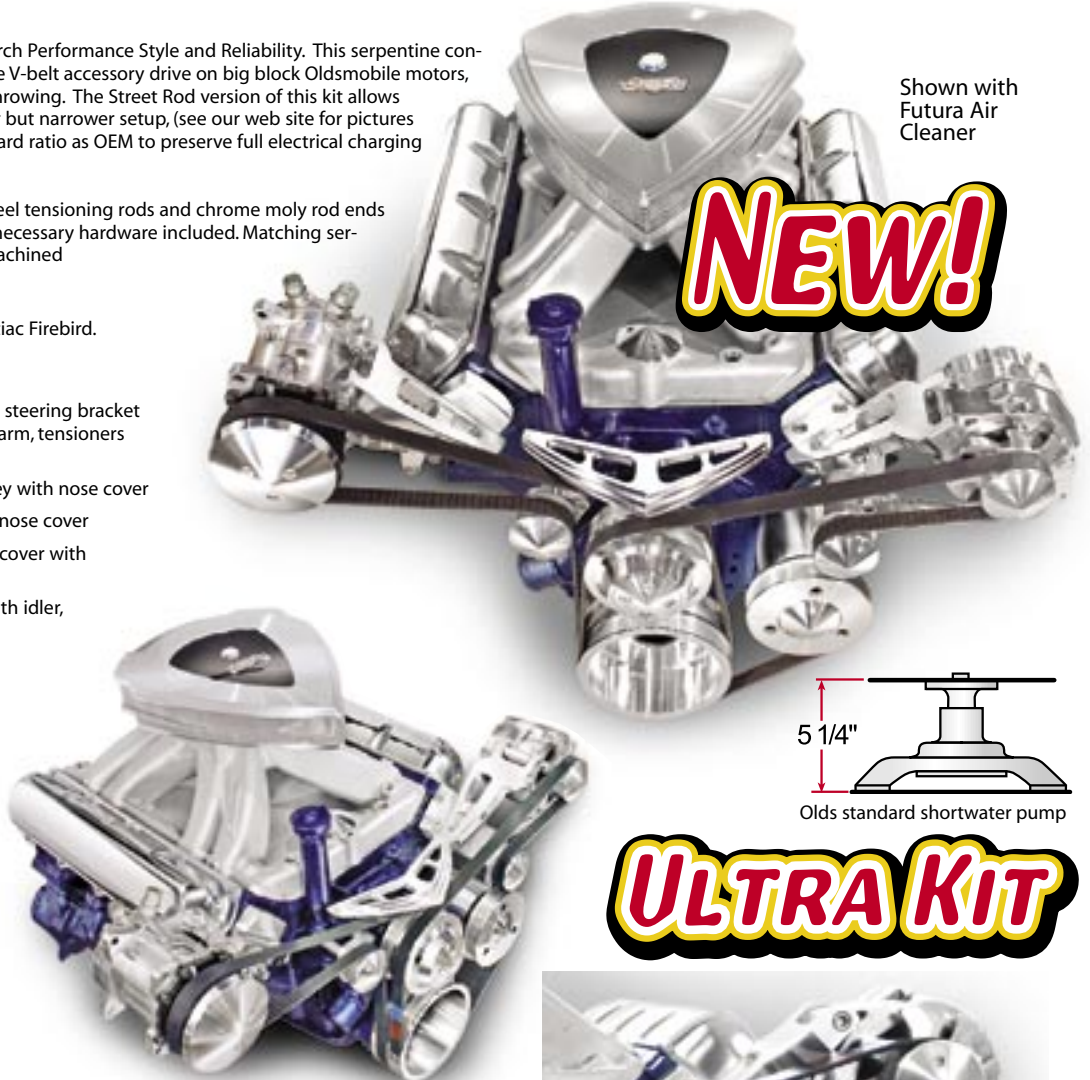

ULTRA KIT

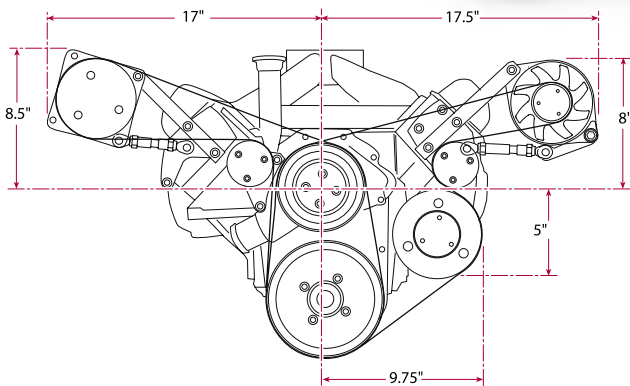

Saginaw Power Steering Pump Kit.
Use your old pump and save the cost of remote power steering lines and reservoir

Oldsmobile 455ci								
Kit #Drives	Alternator	A/C	Water Pump	Remote Reservoir Power Steering	Saginaw Power Steering	Wing Accent	Alt. W/P A/C belt size	Alt. W/P P/S belt size
16070	YES	YES	YES	YES		YES	65"	61.5"
16075	YES		YES	YES		Optional		65"
16090	YES	YES	YES		YES	YES	65"	
16095	YES		YES		YES	Optional		
Type of Accessories	GM 6-12 o'clock mounting 6" or 7" diameter alt.	Sanden 505 or 508 serpentine A/C or March P-410	Olds short forward rotation water pump with 5.25" offset or March #P150 Chrome Water Pump	1987 Sunbird remote reservoir pump	1966-74 Saginaw Keyway pump with canister or March Billet pump		6 Rib	6 Rib