

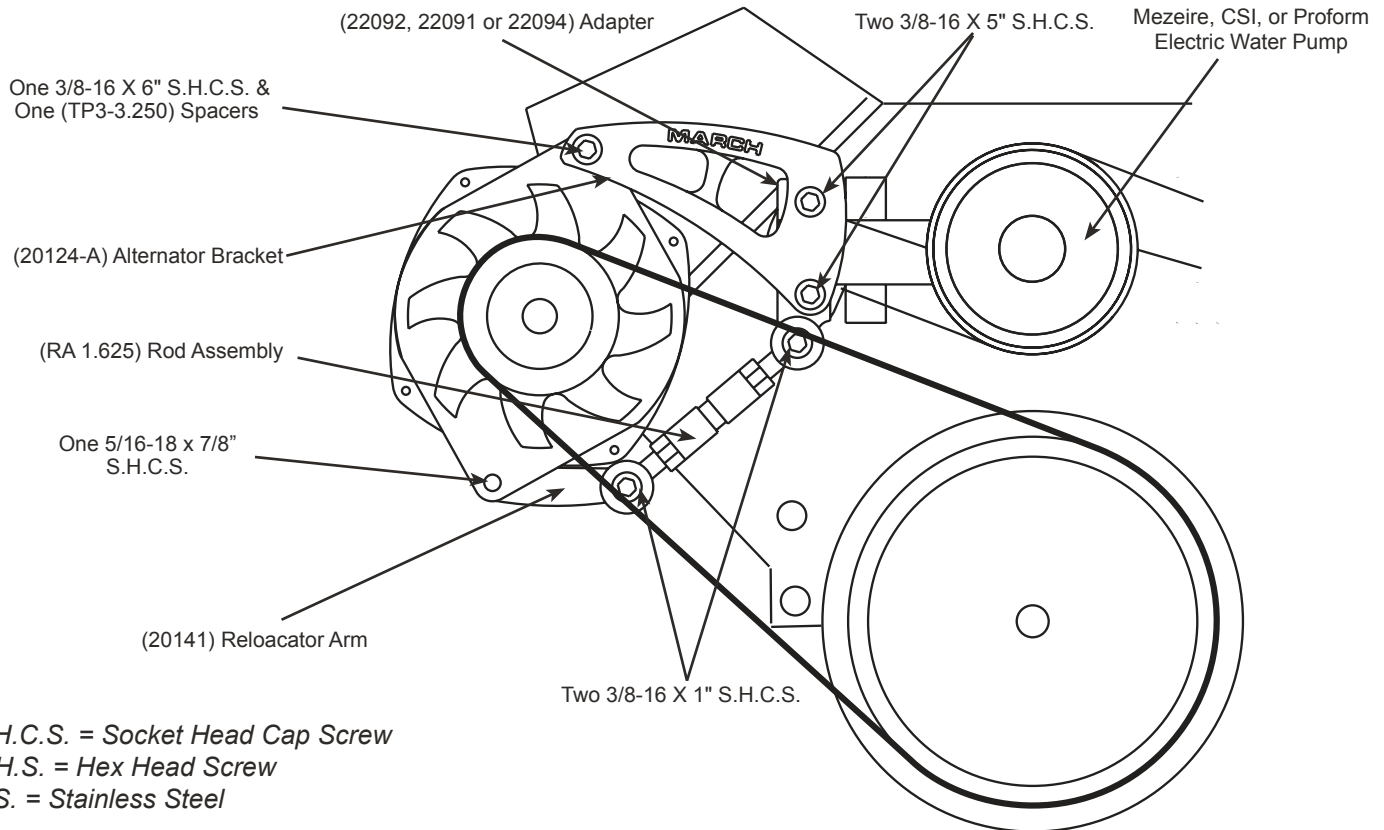

#22003, #22004, #22005, 22006, 22007 Revised 6-4-07

Chevy Small Block Electric Water Pump Alternator

(all except aerospace water pumps)



S.H.C.S. = Socket Head Cap Screw
H.H.S. = Hex Head Screw
S.S. = Stainless Steel

Parts List

- 1- (20124-A) Alt Bracket
- 1- 22091(Mezeire), 22092(CSI), 22094(Proform), Adapter Bracket (between alt bracket & waterpump)
- 1- (RA 1.625) SS Rod Assembly
- 2- (S278) 3/8-16 x 5" SHCS (alt bracket, adapter & waterpump to engine block)
- 1- (TP3 3.250) Spacer (between alternator & head)
- 1- (S282) 3/8-16 x 6" SHCS (alt bracket, alternator to head)
- 2- (S667) 3/8 x 5/8 SS Washers (between head & TP3 3.250 spacer- optional)
- 1- (20141) Relocator
- 2- (S248) 3/8-16 x 1" SHCS (SS Rod to adapter) (SS Rod to relocater)
- 1- (S144) 5/16-18 x 7/8" SHCS (relocator to alternator)

Requires 38" 6-rib serpentine belt

Assembly Instructions

1. Bolt (20124-A) Alternator Bracket & Waterpump to engine block using two 3/8-16 x 5" socket head cap screws & one (22092, 22091 or 22094) Adapter between bracket & waterpump. Do not tighten completely yet.
2. Bolt Alternator to engine head using one 3/8-16 x 6" thru Alternator Bracket & one (TP3-3.250) Spacer between Alternator & engine head. (Note; if using a polished alternator, check the width of the ear on the alternator. If it is less than 2" wide, (S667) Washers may need to be used between alternator & spacer.) Completely tighten all screws.
3. Bolt (20141) Relocator Bracket to Alternator using one 5/16-18 x 7/8" socket head cap screw.
4. Bolt (RA 1.625) Stainless Steel Rod Assembly to Relocator Bracket using one 3/8-16 x 1" socket head cap screw.
5. Install belt.
6. Bolt other end of (RA 2.500) Stainless Steel Rod Assembly to Adapter using one 3/8-16 x 1" socket head cap screw.
7. Adjust belt tension using (RA 1.625) Stainless Steel Rod Assembly.

Chevy Small Block Electric Water Pump Power Steering

(all except aerospace water pumps)

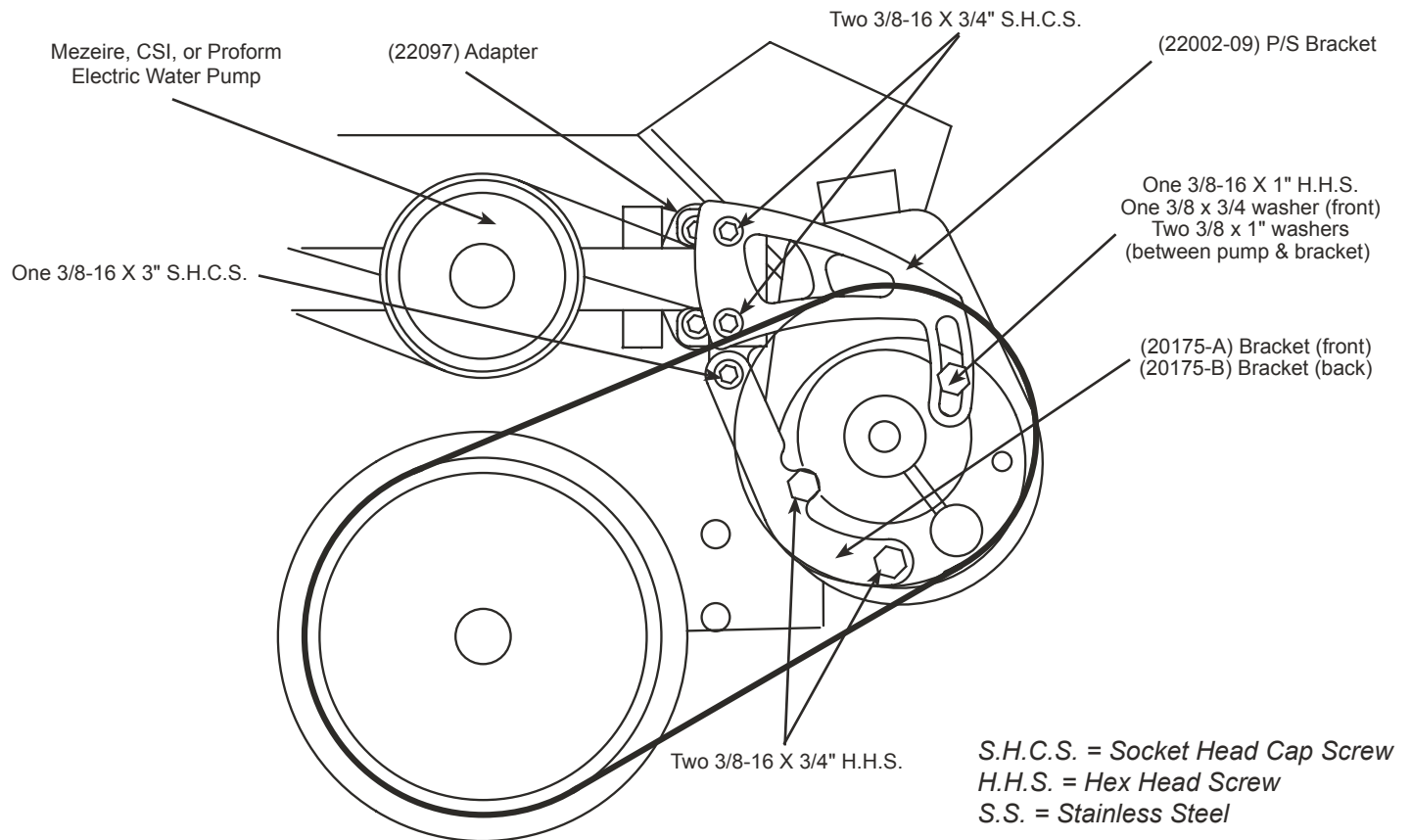

Parts List

- 1- (20145) Power Steering Bracket
- 1- (20175-A) Bracket
- 1- (20175-B) Bracket
- 2- (S244) 3/8-16 x 3/4" SHCS
(P/S bracket to adapter bracket)
- 2- (S252) 3/8-16 x 1 1/2" SHCS
(adapter bracket & waterpump to engine block)
- 1- (S266) 3/16-16 x 3" SHCS
(20175-A & B to adapter bracket)
- 3- (S311) 3/8-16 x 3/4" HHS (20175-A bracket to
P/S pump x2)(20175-B bracket to P/S pump x1)
- 1- (S312) 3/8-16 x 1" HHS
(20145 P/S bracket to P/S pump)
- 1- (S666) 3/8 x 3/4" washer
(between S312 & 20145 P/S bracket)
- 2- (S664) 3/8 x 1" washer (betwwen P/S pump &
20145 P/S bracket)

Requires 37" 6-rib serpentine belt

Assembly Instructions

1. Bolt Adapter Bracket & Waterpump to engine block using two (S252) 3/8-16 x 1 1/2" socket head cap screws.
2. Bolt (20145-A) Power Steering Bracket to Adapter Bracket two (S244) 3/8-16 x 3/4" socket head cap screws.
3. Bolt (20175-A) Bracket to front of Power Steering Pump using two (S311) 3/8-16 x 3/4" hex head screws.
4. Bolt (20175-B) Bracket to back of Power Steering Pump using one (S311) 3/8-16 x 3/4" hex head screw.
5. Bolt (20175-A & B) Bracket to Adapter Bracket using one (S266) 3/8-16 x 3" socket head cap screw.
6. Bolt (20145-A) Power Steering Bracket to Power Steering Pump using one (S312) 3/8-16 x 1" hex head screw & one (S666) 3/8 x 3/4" washer, place two (S664) 3/8 x 1" washers between (20145-A) Power Steering Bracket & power steering pump. Leave loose for adjustment.
7. Mount Power Steering Pulley to Power Steering Pump.
8. Install belt & adjust tension by pulling up on Power Steering Pump.
9. Lock the belt tension by tightning the adjustment screw with a 9/16" opened end wrench.